

ACCELEROMETER FUNDAMENTALS



TABLE OF CONTENTS

ICP® AND CHARGE ACCELEROMETERS	4 – 5
ELECTRONICS FOR ICP® AND CHARGE ACCELEROMETERS	6 – 7
MOUNTING CONSIDERATIONS AND AMPLITUDE RANGE	8 – 9
FREQUENCY RESPONSE AND RANGE OF ICP® AND CHARGE ACCELEROMETERS	10 – 11
SEISMIC ACCELEROMETERS	12 – 13
MEMS ACCELEROMETERS	14 – 15

ICP® AND CHARGE ACCELEROMETERS

THEORY OF OPERATION

Piezoelectric accelerometers measure vibration and shock for a wide variety of applications. They incorporate a piezoelectric sensing element with a crystalline atomic structure which outputs an electrical charge when subjected to a load with near zero deflection. The charge output occurs instantaneously, (making them ideal for dynamic applications) but is subject to decay and therefore not capable of static measurements.

PCB® accelerometers typically utilize a shear configuration where the sensing element and seismic mass are mechanically preloaded around a center post/base via a preload ring as shown in the below graphic. This produces a stiff structure with good frequency response and minimizes influence from the mounting surface (strain and thermal).

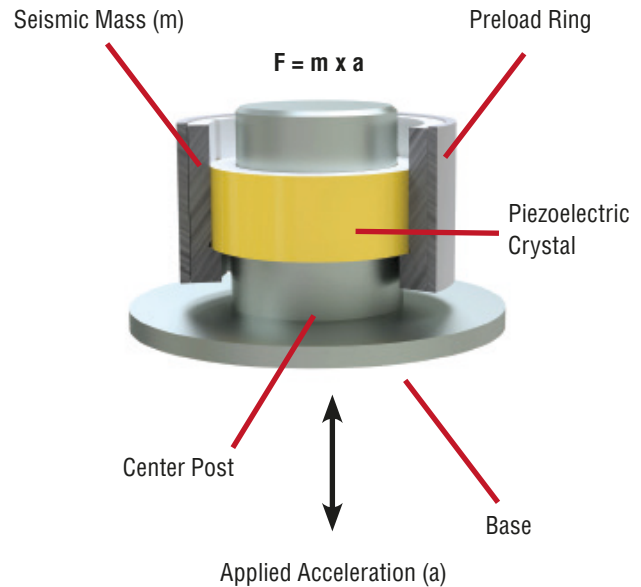

TWO MAIN TYPES OF PIEZOELECTRIC ACCELEROMETERS

- **ICP®** - Identifies PCB® sensors that incorporate built-in microelectronics. The ICP® electronics convert a high-impedance charge signal generated by a piezoelectric sensing element into a usable low-impedance voltage signal when powered with constant current. The modified signal can be readily transmitted over two-wire or coaxial cables to data acquisition systems or readout devices.
- **Charge mode** - The output of a charge mode accelerometer is a high impedance signal which is dependent on electrical insulation for low loss / low noise transmission. It should be converted to a low impedance signal prior to the data acquisition system or readout device. It is important to use low noise cables and avoid using cables with insulation damage or contamination.

ICP® ADVANTAGES

- Simple to operate
- Able to operate in dirty environments over long cable runs
- Uses integral power from all manufacturers' data acquisition systems (may require specific module)

ICP® DISADVANTAGES

- Maximum operating temperature of 356 °F (180 °C)
- Sensitivity and low frequency response are not adjustable
- Requires ICP® fixed-current power

CHARGE MODE ADVANTAGES

- Operating temperature up to +1,200 °F (+650 °C) for UHT-12™ element with hardline cable
- Flexibility in adjusting accelerometer output characteristics
- Extended low frequency response with long time constant

CHARGE MODE DISADVANTAGES

- Additional cost of required charge amplifier or charge converter
- Sensor and cable connections must be kept clean and dry for best performance
- Requires more costly, low noise cable

TYPICAL PCB® ACCELEROMETER

ICP® MICROELECTRONICS

Converts high impedance output from the piezoelectric crystal to a low impedance voltage output

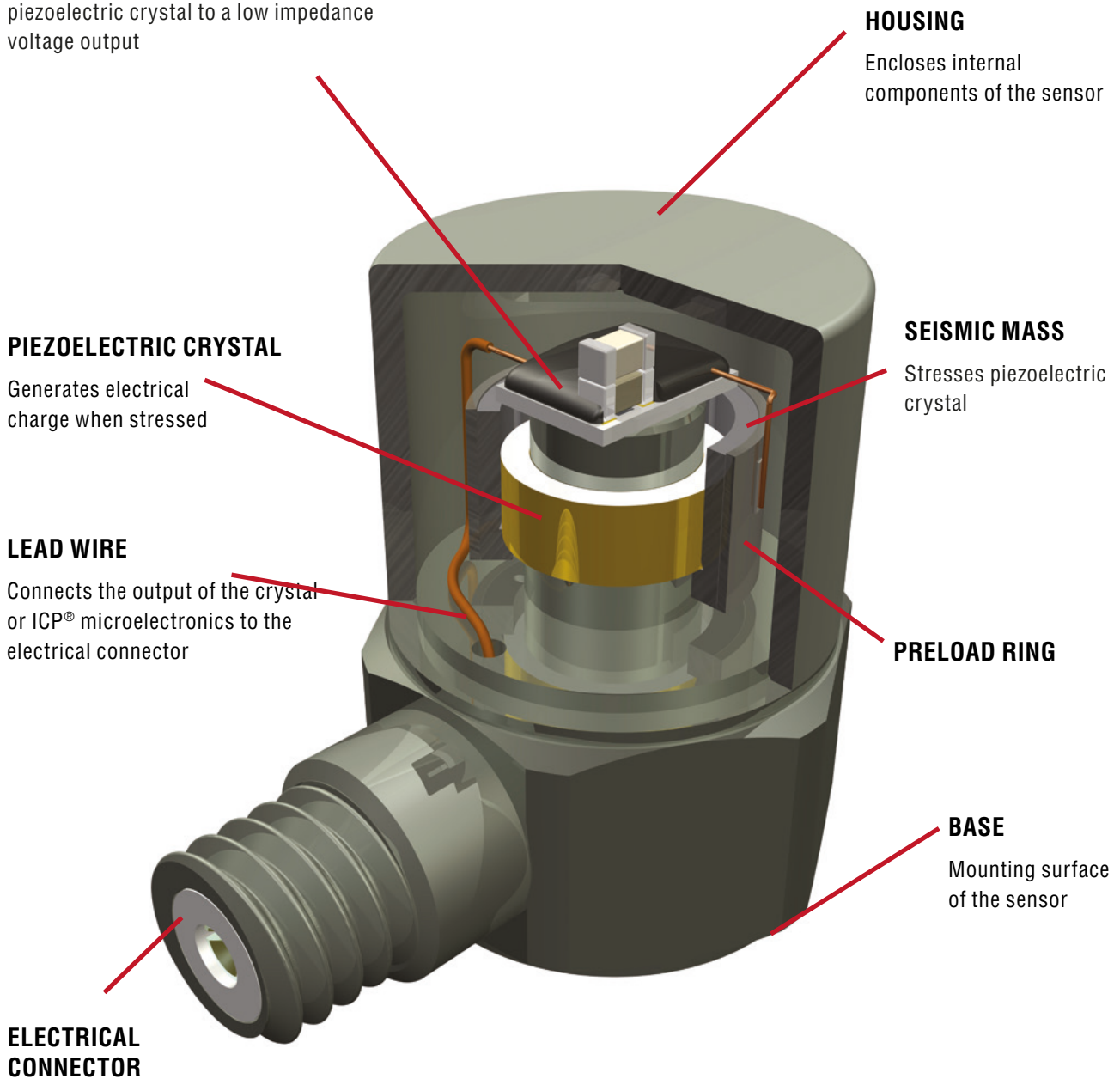

ELECTRONICS FOR ICP® AND CHARGE ACCELEROMETERS

ICP® accelerometers must be powered from a constant-current DC voltage source (see specific sensor datasheet for turn-on voltage). Once powered, the electronics within an ICP® sensor convert piezoelectric charge to a low impedance signal with power and output on the same channel. ICP® signal conditioners or ICP® configured readout devices will remove the power portion of the signal, resulting in full scale output of ± 5 volts.

PCB offers multiple ICP® signal conditioners from 1 to 16 channels with current adjustment within 2 - 20 mA at +18 to +30 volts DC. Refer to PCB Tech Note TN-32 for more information on signal conditioners and impedance. Do not attempt to power ICP® sensors with commercially available power supplies as unregulated current will damage the sensors' internal electronics.



ICP® Accelerometer



General Purpose Cable



Signal Conditioner for ICP® Power
(Conditioned output to Oscilloscope or DAQ)

When a data acquisition system includes ICP® power, a separate signal conditioner is not required.



ICP® Accelerometer



General Purpose Cable



Digital Oscilloscope or DAQ
(External module for ICP® Power not shown)

CHARGE ACCELEROMETER INSTRUMENTATION

Charge mode accelerometers' high impedance signal requires conversion to a low impedance voltage signal prior to being processed by data acquisition or readout devices. The conversion can be done in two ways:



Charge Mode Accelerometer



Low Noise Cable



Dual Mode Charge Amplifier
(Low impedance output to Oscilloscope or DAQ)

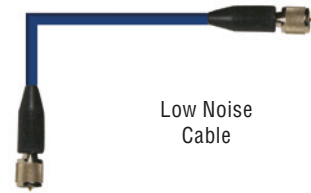

Low Noise Cable



In-line Charge Converter

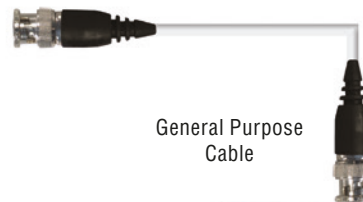

General Purpose Cable



Charge Mode Accelerometer



ICP® Signal Conditioner - Powers Charge Converter
(Low impedance output to Oscilloscope or DAQ)

MOUNTING CONSIDERATIONS AND AMPLITUDE RANGE

PROPER CABLE MOUNTING & STRAIN RELIEF

Install cables to minimize connector strain using tape or clamps with service loops. This will maximize cable life and may also reduce cable-born, triboelectric noise.

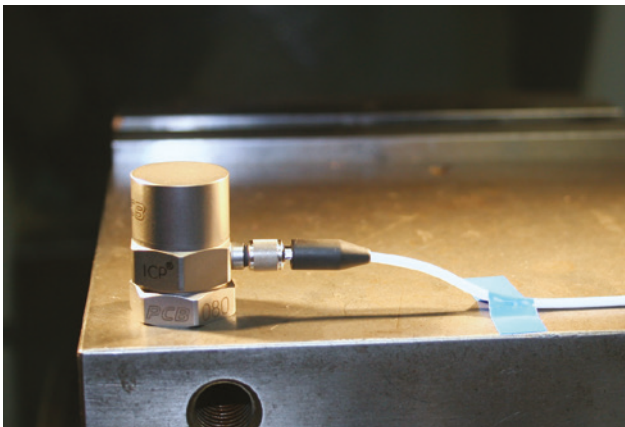
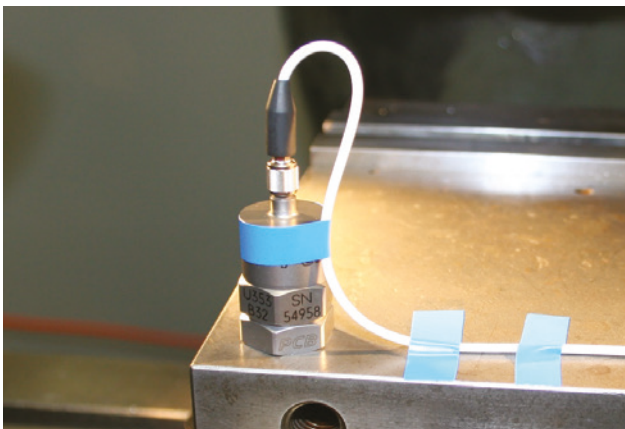

MOUNTING TECHNIQUES

There are a variety of mounting techniques for accelerometers. Each method influences the achievable high frequency measurement range.

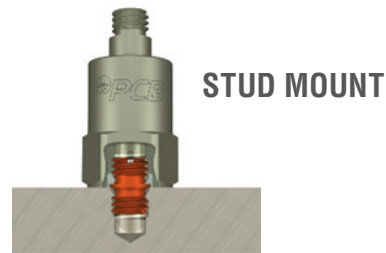

Stud mounting (integral or tapped hole) preferred for greatest rigidity.

- This method provides excellent high frequency response



Adhesive mounting bases can be used when other techniques are not practical.

- Some adhesives have limited use in higher temperature applications

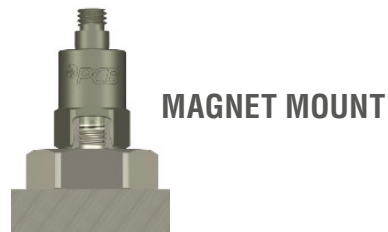

Used for temporary mounting or on curved surfaces.

- Magnets can limit the useable frequency range of the accelerometer

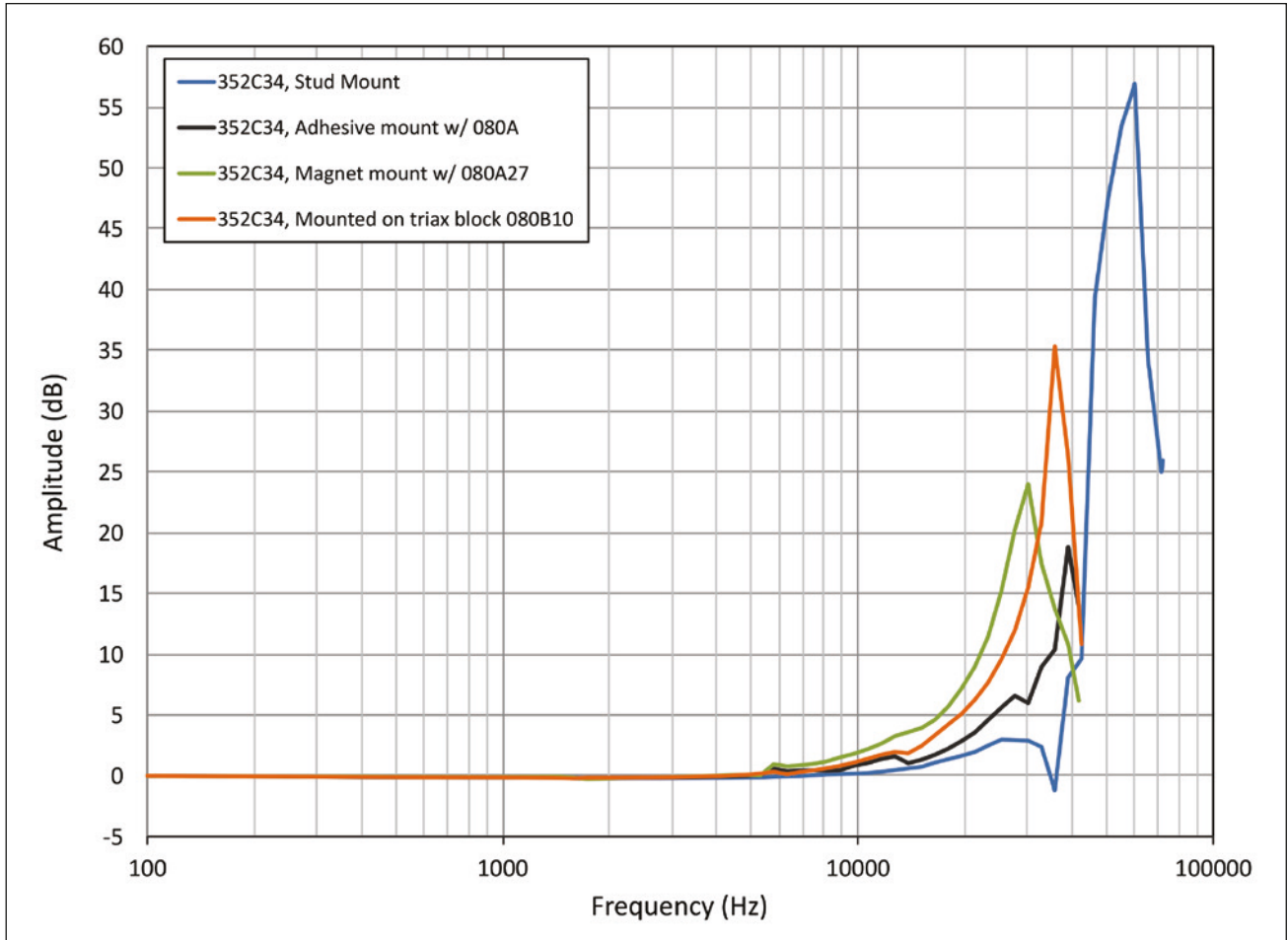

AMPLITUDE RANGE OF PCB® ACCELEROMETERS

Most ICP® accelerometers have a full scale output voltage of ± 5 volts DC. Charge accelerometers are not limited to a maximum 5 volt DC full scale output range, they can operate anywhere within the linear measurement range listed on the specification sheet. The charge output (pC/g) can then be converted by a charge amplifier or charge converter (mV/pC). Laboratory amplifiers typically have the ability to adjust gain (mV/pC) and measurement range. In-line charge converters typically have a fixed gain and measurement range.

ICP® Measurement Output

Accelerometer Sensitivity (AS): 10 mV/g

Peak Measurement (G_{max}): ± 500 g

$$\text{Output (VDC)} = AS \times G_{max} \\ = 10 \text{ mV/g} \times 500 \text{ g}$$

Output = 5,000 mV = 5.0 VDC

Charge Measurement Range

The max acceleration measurable with this sensor & converter combination

Accelerometer Sensitivity (AS): 10 pC/g

Converter Input Range (CI): ± 500 pC

$$\text{Range } (\pm \text{g}) = AS \div CI \\ = \pm 500 \text{ pC} \div 10 \text{ pC/g}$$

Range = ± 50 g

Charge Gain Conversion

Accelerometer Sensitivity (AS): 10 pC/g

Measurement Input (G_m): 14 g

Charge Conversion (CC): 10 mV/pC

$$\text{Output (VDC)} = AS \times G_m \times CC \\ = 10 \text{ pC/g} \times 14 \text{ g} \times 10 \text{ mV/pC}$$

Output = 1,400 mV = 1.4 VDC

FREQUENCY RESPONSE

DISCHARGE TIME CONSTANT

- Discharge Time Constant (DTC) is the time (usually in seconds) required for an AC coupled device or measuring system to discharge its signal to 37% of the original value from a step change of measurand.
- Follows RC circuit principles where an instantaneous charge immediately begins dissipating at an exponential rate.
- ICP[®] sensors have fixed DTC based on the values of the internal RC network. When used in AC coupled systems, (sensor, cable, and ICP[®] signal conditioner) the sensor will take on the DTC characteristics of the ICP[®] sensor or signal conditioner (whichever is shortest). In charge mode sensors, the DTC is dictated by choice of charge amplifier or in-line charge converter and system resistance/capacitance.

Where:

- q = instantaneous charge (pC)
- Q = initial quantity of charge (pC)
- R = bias (or feedback) resistor value (ohms)
- C = total (or feedback) capacitance (pF)
- t = any time after t_0 (sec)
- e = base of natural log (2.718)

LOW FREQUENCY RESPONSE

In ICP[®] sensors, the low frequency response is dictated by the sensor electronics. Charge mode sensors do not include low frequency response or DTC in their specifications because they are dependent on the specific charge converter or amplifier used. When using charge mode sensors, refer to the specifications of the specific signal converter for low frequency and time constant information.

ICP[®] sensors have internal microelectronics that perform the conversion from a high impedance charge to a low impedance voltage signal. The low frequency roll off characteristics are included on ICP[®] sensor datasheets. Example specifications are included in the table on the next page.

The graphic below shows the relationship between sensitivity and frequency:

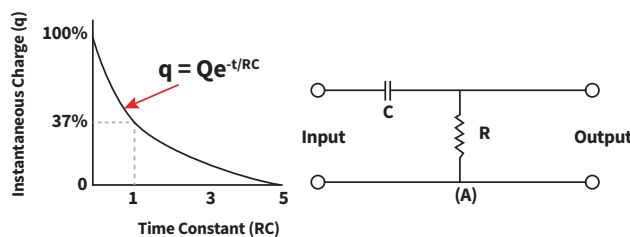
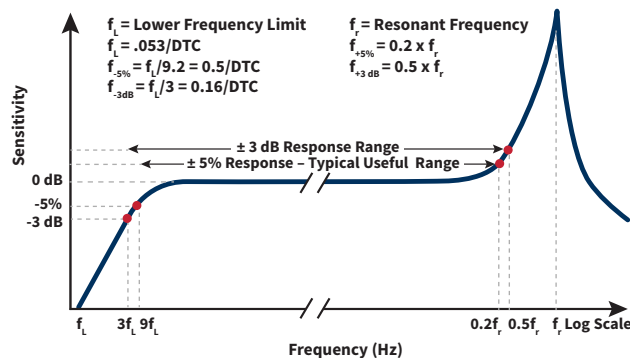

HIGH FREQUENCY RESPONSE

Accelerometers generally exhibit increased sensitivity when internal elements are excited by vibratory loads at higher frequencies, peaking at the resonant frequency. This results from the coupled stiffness of relatively small components in accelerometer assemblies. Sensitivity rises rapidly as the resonant frequency is approached, which can result in signal saturation. Measurement error from resonance is avoided by setting a measurement frequency limit - commonly set at 20% of the resonant frequency.

Filtering is implemented in some ICP[®] accelerometers to attenuate the effects of resonance for operation closer to resonant frequency. Both upper and lower frequency limits must be taken into account to determine appropriate measurement limits for any test (ex: ± 5% or ± 3dB).

TYPICAL PERFORMANCE SPECIFICATIONS

ICP® Accelerometer	Model 352C22	
Sensitivity ($\pm 20\%$)	10 mV/g	1.0 mV/(m/s ²)
Measurement Range	± 500 g pk	± 4900 m/s ² pk
Frequency at -5 %	1.0 Hz	
Frequency at +5 %	10,000 Hz	
Frequency at -3 dB	0.3 Hz	
Frequency at +3 dB	20,000 Hz	
Resonant Frequency	≥ 50 kHz	
Environmental		
Temperature Range (Operating)	-65 to +250 °F	-54 to +121 °C
Electrical		
Excitation Voltage	18 to 30 VDC	
Output Bias Voltage	7 to 12 VDC	
Discharge Time Constant	1.0 to 3.5 sec	

Charge Accelerometer	Model 357C10	
Sensitivity ($\pm 20\%$)	1.7 pC/g	0.17 pC/(m/s ²)
Measurement Range	± 500 g pk	± 4900 m/s ² pk
Frequency at -5 %	Low frequency response is determined by external signal conditioning electronics.	
Frequency at +5 %	10,000 Hz	
Frequency at -3 dB	Low frequency response is determined by external signal conditioning electronics.	
Frequency at +3 dB	20,000 Hz	
Resonant Frequency	≥ 50 kHz	
Environmental		
Temperature Range (Operating)	-100 to +350 °F	-73 to +177 °C

EFFECT OF EXCITATION VOLTAGE ON THE DYNAMIC RANGE OF ICP® SENSORS

The specified excitation voltage for all standard ICP® sensors and amplifiers is generally within the range of +18 to +30 volts. The effect of this range is shown in the chart at right.

To explain the chart, the following values will be assumed:

V_B = Sensor Bias Voltage = 10 VDC

V_{S1} = Supply Voltage 1 = 24 VDC

V_{E1} = Excitation Voltage 1 = $V_{S1} - 1 = 23$ VDC

V_{S2} = Supply Voltage 2 = 18 VDC

V_{E2} = Excitation Voltage 2 = $V_{S2} - 1 = 17$ VDC

Note that an approximate 1 volt drop across the current limiting diode (or equivalent circuit) must be maintained for correct current regulation.

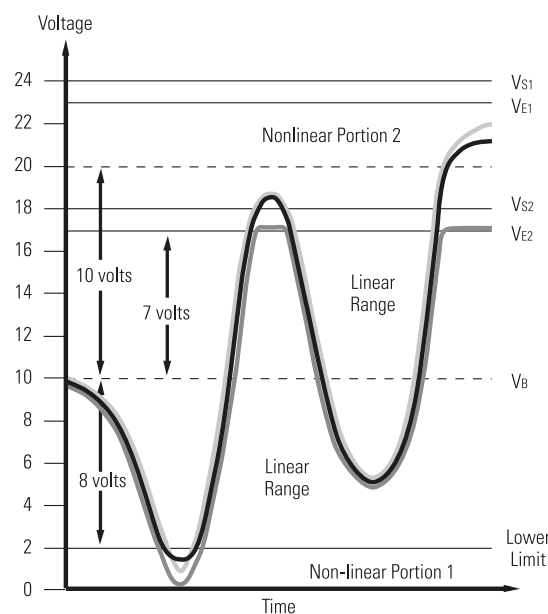
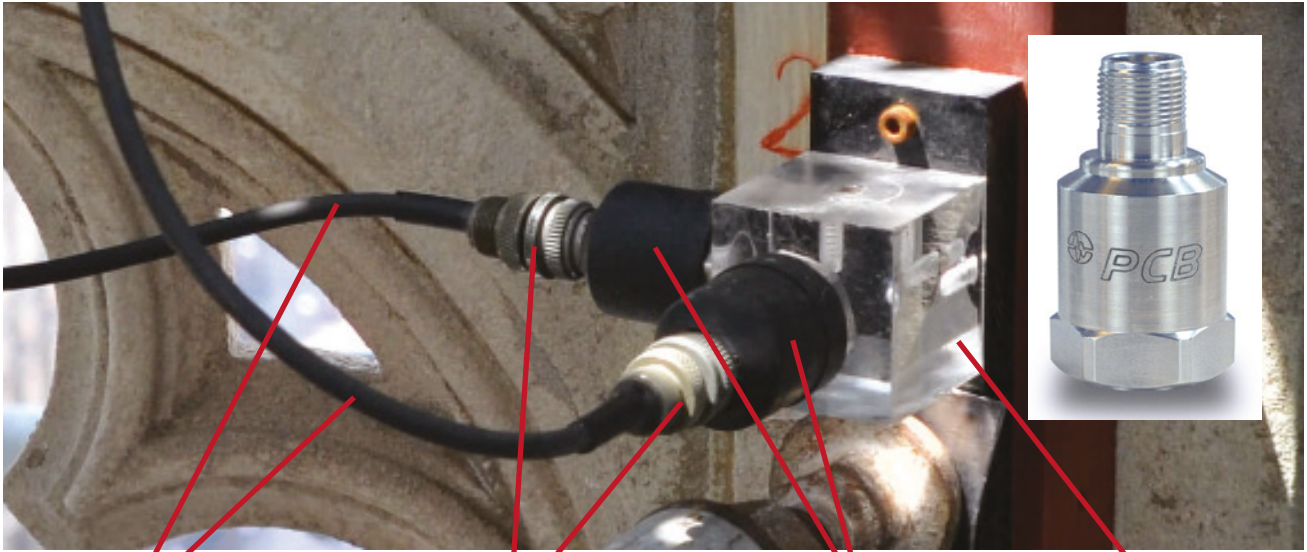

Figure 9.

- Input Measurand (signal)
- - - Output Signal (18 VDC supply)
- · · Output Signal (24 VDC supply)

SEISMIC ACCELEROMETERS



2-conductor, shielded twisted pair cable inside of polyurethane jacket

2-pin MIL connectors used with case isolated seismic accelerometers

Protective Thermal Jacket

Mounting Block

HIGH SENSITIVITY ICP® ACCELEROMETERS FOR SEISMIC APPLICATIONS

High sensitivity ICP® accelerometers are used to detect ultra-low amplitude, low-frequency vibrations associated with very large structures, foundations, and earth tremors. These sensors possess exceptional measurement resolution due to their comparatively large size, which provides a higher output signal and a lower noise floor.

High sensitivity accelerometers generate signals in response to a variety of vibration sources including: traffic, wind, and programmatic impulse. When analyzed, these signals provide insight for determining the condition and safety of the structure. This investigative analysis can lead to recommendations for remedial construction or further monitoring. Please note that high sensitivity accelerometers must be handled with care. They contain larger than typical seismic masses that may be damaged if dropped as little as a few inches.

SENSOR ISOLATION AND GROUND LOOP PREVENTION

Instrumentation of electrical devices (circuits, motors, solenoids, etc.) or devices that can generate electrical charge (generators, devices containing conductive media, etc.) require special consideration. Ground loops can occur when the instrumentation cable shield is grounded at two points of differing electrical potential. The shield conveys the electrical potential as AC current which can show up as 50/60 Hz noise.

Sensors are available with Case Isolation or Ground Isolation (via integral isolation or through special mounting bases). Some isolation is provided by adhesive mounting but it varies on the thickness, parallelism, and on the type of adhesive used.

CASE ISOLATION

The sensing element is isolated from the sensor housing.

- Since the signal and signal ground are internally isolated, the cable shield is floated at the sensor end to prevent ground loops
- The shield is grounded only at the readout device
- Sensor can be placed directly on the device under test, no additional base isolation needed
- A two-conductor cable must be used for power and signal transmission

1. Signal Ground
2. Output Signal & Power (+)
3. Capacitor provides ESD protection and RFI filtering
4. Faraday cage shields against environmental noise
5. Case Ground, thru mounting base
6. Coated pad electrically isolates sensing element from outer case

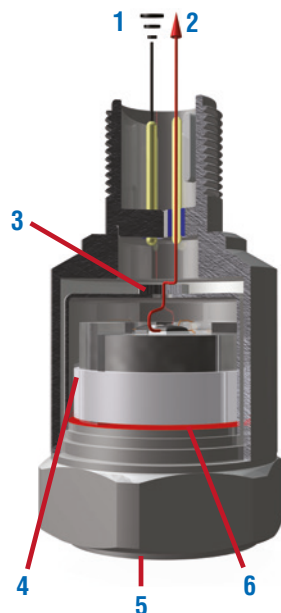

GROUND ISOLATION

Sensor is isolated from mounting surface with an electrically non-conductive material with high insulation resistance.

- Integral Isolation – Incorporate a non-conductive layer isolating the inner sensor from the outer housing
- Anodized Aluminum Isolation - Sensor models that are black in color use anodized aluminum housings for isolation, but potentially degrade with coating wear
- Base Isolation – Some accelerometers incorporate an integral isolation mount or models with female threads can add an isolation base – both shown below
- The above isolation methods require a cable with at least 1 conductor per channel plus the shield. Use of 2-conductor cables with 1 conductor for signal ground is best practice (shielding optional)



MEMS ACCELEROMETERS

THEORY OF OPERATION

MEMS applies to Micro-Electro-Mechanical System; where micro-fabrication methods are used to construct mechanical sensing elements at the microscopic level from silicon materials. Unlike Charge & ICP[®] accelerometers, MEMS accelerometers can measure frequencies down to 0 Hz (static or DC acceleration).

PCB[®] offers two types of MEMS accelerometers: Variable Capacitive (VC) & Piezoresistive (PR). VC MEMS accelerometers are lower range, high sensitivity devices used for structural monitoring and constant acceleration measurements. PR MEMS accelerometers have measurement ranges for the higher 'G' levels used in shock and blast applications, with lower sensitivity and damping.

MEMS VC SENSING ELEMENT

- A micro-machined proof mass is suspended between two parallel plates forming upper and lower air gaps. An electrical charge is applied across the gaps, making them pseudo-capacitors. Motion excites the proof mass, causing a change in gap height and a corresponding change in capacitance. The capacitance change is scaled into a DC output proportional to the acceleration.

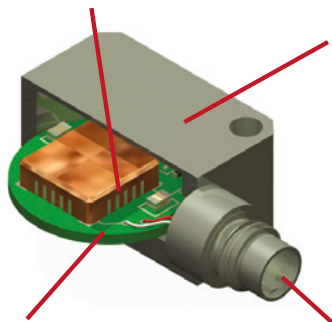

HOUSING

- Provides hermetic sealing of sensors

PRINTED CIRCUIT BOARD

- For voltage regulation, protection, and temperature compensation
- Conditioning circuitry provides a high sensitivity output
- Compensates for zero bias and sensitivity errors over temperature

ELECTRICAL CONNECTOR

- Connects to mating cable for signal transmission and power

MEMS VC ACCELEROMETER FUNCTION AND OPERATION

- To take advantage of the DC response of VC MEMS accelerometers, the signal conditioner readout device must be DC coupled.
- The DC offset voltage will be affected by the positional alignment relative to the Earth's gravity due to the VC MEMS accelerometers ability to measure static (constant) acceleration.
- When the sensitive axis of the accelerometer is perpendicular to gravity, the output will equal the zero-G offset voltage on the PCB[®] calibration certificate.
- When the sensitive axis of the accelerometer is aligned with gravity, the output will be equal to the bias voltage +1g of output.

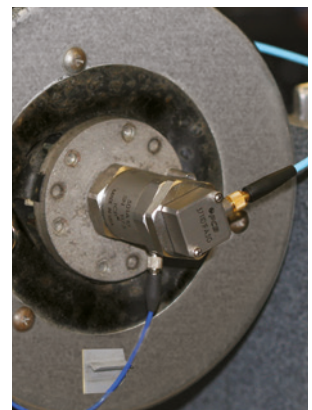

MEMS VC ACCELEROMETER VERIFICATION

- An accurate static calibration can be performed using the Earth's gravity as the acceleration reference. Place the accelerometer in a +1g orientation so that the base is resting on the mounting surface and the model number is facing up.
- Invert the sensor by flipping it 180°, placing the model number face down on the mounting surface. The sensor should output -1g acceleration.

MEMS PR SENSING ELEMENT

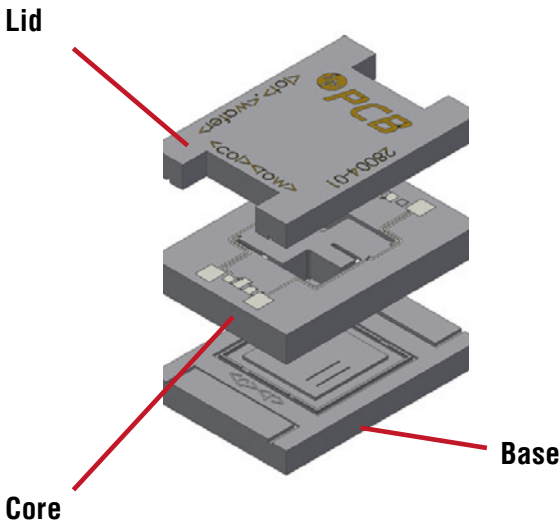

- The sensing elements and seismic mass are comprised of flexures on a middle layer sandwiched between upper and lower layers.
- The bending of these flexures causes a measurable change in resistance that is proportional to the applied acceleration.
- Different measurement ranges are achieved by using different flexures, changing the stiffness of the sandwich.
- Gas damping lowers resonant amplification and reduces the response to high frequency energy.

MEMS PR ACCELEROMETER FUNCTION AND OPERATION

- To take advantage of the DC response of MEMS accelerometers, the signal conditioner and readout device must be in a DC coupled state.
- PR accelerometers should be powered with a regulated voltage source because sensitivity is proportional to excitation voltage. The recommendation is to use the excitation voltage listed on the calibration certificate to obtain the calibrated sensitivity value.
- The sensing elements are arranged in a fully active Wheatstone bridge configuration. The bridge uses variable resistors, two that increase with the input acceleration or force, and two that decrease.

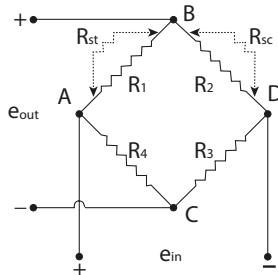

MEMS PR ACCELEROMETER VERIFICATION

- To check the output offset voltage connect the +Exc and -Exc leads to an appropriate power supply. Connect the +Sig and -Sig leads to a volt meter that is set to read VDC.
- Mount the sensor in a +1g orientation so that it is resting securely on a flat, level and stable surface. Measure the differential voltage output of the sensor. Check the calibration certificate for verification of the measured offset voltage.
- To check the bridge resistance use an ohmmeter or set a digital multimeter to measure resistance in ohms. Rest the sensor on a flat and level surface. There is no need to apply an excitation voltage for this test. The input resistance is measured between the +Exc and -Exc wires. The output resistance is measured between the +Sig and -Sig wires. Check the calibration certificate for verification of the measured resistance values.



