

FORCE & STRAIN FUNDAMENTALS

TABLE OF CONTENTS



| | |
|--|---------|
| ICP® AND CHARGE FORCE SENSORS | 4 – 5 |
| ELECTRONICS FOR ICP® AND CHARGE FORCE SENSORS | 6 – 7 |
| FORCE SENSOR INSTALLATION | 8 – 9 |
| FREQUENCY RESPONSE AND RANGE OF ICP® AND CHARGE FORCE SENSORS | 10 – 11 |
| STRAIN SENSORS | 12 – 13 |
| FORCE SENSOR OR LOAD CELL? | 14 – 15 |

ICP[®] AND CHARGE FORCE SENSORS

THEORY OF OPERATION

Piezoelectric force sensors measure compressive or tensile loads for a wide variety of applications. They incorporate a piezoelectric sensing element with a crystalline atomic structure which outputs an electrical charge when subjected to force with near zero deflection. The charge output occurs instantaneously, making piezoelectrics ideal for dynamic applications but subject to decay and therefore not capable of static measurements.

PCB[®] force sensors are constructed with thin quartz crystal discs as the piezoelectric sensing elements which are "sandwiched" between upper and lower base plates. The base plates are compressively loaded together to a specific preload setting and retained by either a preload stud (threaded) or preload sleeve (welded). The sensing elements are preloaded, allowing for tensile measurements. Electrodes on the sensing elements transfer the electrical charge to internal ICP[®] electronics or directly to the electrical connector in charge models.

The outer housing aligns internal components, provides structural support for the electrical connector, and is hermetically welded to the base plates for ingress protection. This compressively loaded stack results in extraordinary stiffness for precision measurement under dynamically cycling loads.

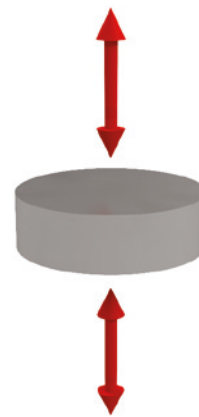

SENSOR CONSTRUCTION

PIEZOELECTRIC CRYSTAL

Quartz crystal that generates electrical charge when stressed

IMPACT CAP

Spreads applied force over entire surface of sensor

PRELOAD STUD

Sensing elements are compressed, allowing for tensile measurements

ICP[®] MICROELECTRONICS

Converts the charge output from the piezoelectric crystal to a low impedance voltage output (not present in charge mode force sensors)

INSULATOR

Insulates the output signal from the sensor housing

ELECTRICAL CONNECTOR

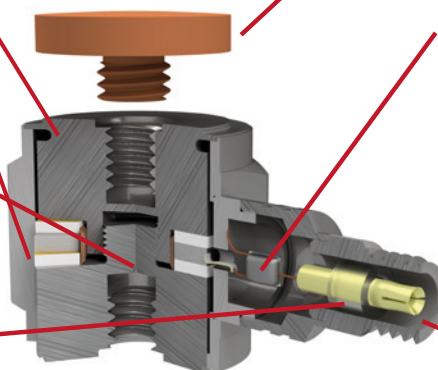

TWO MAIN TYPES OF PIEZOELECTRIC FORCE SENSORS

- ICP® - Identifies PCB sensors that incorporate built-in microelectronics. The ICP® electronics convert a high-impedance charge signal generated by a piezoelectric sensing element into a usable low-impedance voltage signal when powered with constant current. The modified signal can be readily transmitted over two-wire or coaxial cables to data acquisition systems or readout devices.
- Charge mode - The output of a charge mode force sensor is a high impedance signal which is dependent on electrical insulation for low loss / low noise transmission. It should be converted to a low impedance signal prior to the data acquisition system or readout device. It is important to use low noise cables and avoid using cables with insulation damage or contamination.

ICP® ADVANTAGES

- Simple to operate
- Able to operate in dirty environments over long cable runs
- Uses integral power from all manufacturers' data acquisition systems (may require specific module)

ICP® DISADVANTAGES

- Maximum operating temperature of 250 °F (121 °C)
- Sensitivity and low frequency response are not adjustable
- Requires ICP® constant-current power

CHARGE MODE ADVANTAGES

- Operating temperature up to 400 °F (204 °C)
- Flexibility in adjusting output characteristics
- Extended low frequency response with long time constant charge amps

CHARGE MODE DISADVANTAGES

- Additional cost of required charge amplifier or charge converter
- Sensor and cable connections must be kept clean and dry for best performance
- Requires more costly, low noise cable

AMPLITUDE RANGE OF PCB FORCE SENSORS

Most ICP® force sensors have a full scale output voltage of ±5 volts. Charge force sensors are not limited to a maximum 5 volt full scale output range, they can operate anywhere within the linear measurement range listed on the specification sheet. The charge output (pC/lb force) can then be converted by a charge amplifier or charge converter (mV/pC). Laboratory amplifiers typically have the ability to adjust gain and measurement range. In-line charge converters typically have a fixed gain and measurement range.

ICP® Measurement Output

Force Sensitivity (FS): 500 mV/lb

Measurement Range (MR): 10 lb compression

Signal Output (V_{out}) = FS x MR

$$= 10 \text{ mV/g} \times 500 \text{ g}$$

$$V_{out} = 5,000 \text{ mV} = 5.0 \text{ volts}$$

Output = 5,000 mV = 5.0 VDC

Charge Measurement Range

The max force measurable with this sensor and converter combination

Force Sensitivity (FS): 18 pC/lb

Converter Input Range (CI): ± 5,000 pC

Measurable Force (MF_{max}) = CI ÷ FS

$$= \pm 500 \text{ pC} \div 10 \text{ pC/g}$$

$$= \pm 5,000 \text{ pC} \div 18 \text{ pC/lb}$$

$$MF_{max} = \pm 277.8 \text{ lb}$$

(Necessary preload must be considered for tension)

Charge Gain Conversion

Force Sensitivity (FS): 18 pC/lb

Force Input (F_{in}): 75 lb

Charge Conversion (CC): 1 mV/pC

Signal Output (V_{out}) = FS x F_{in} x CC

$$= 18 \text{ pC/lb} \times 75 \text{ lb} \times 1.0 \text{ mV/pC}$$

$$V_{out} = 1,350 \text{ mV} = 1.4 \text{ volts}$$

Conversion Units

1 lb (pound force) = 4.45 N (newton)

1,000 lb = 4500 N = 4.45 kN

ELECTRONICS FOR ICP® AND CHARGE FORCE SENSORS

ICP® FORCE SENSOR INSTRUMENTATION

ICP® force sensors must be powered from a constant-current DC voltage source (see specific sensor datasheet for turn-on voltage). Once powered, the electronics within an ICP® sensor convert piezoelectric charge to a low impedance signal with power and output on the same channel. ICP® signal conditioners or ICP® configured readout devices will remove the power portion of the signal, resulting in full scale output of ± 5 volts.

PCB offers multiple ICP® signal conditioners from 1 to 16 channels with current adjustment within 2-20 mA at +18 to +30 volts DC. Refer to PCB Tech Note TN-32 for more information on signal conditioners and impedance. Do not attempt to power ICP® sensors with commercially available power supplies as unregulated current will damage the sensors' internal electronics.



ICP® Force Sensor



General Purpose Cable



Signal Conditioner for ICP® Power (Conditioned output to Oscilloscope or DAQ)

When a data acquisition system (DAQ) includes ICP® power, a separate signal conditioner is not required.



ICP® Force Sensor



General Purpose Cable



Digital Oscilloscope or DAQ
(External module for ICP® power not shown)

CHARGE FORCE SENSOR INSTRUMENTATION

Charge mode sensors' high impedance signal requires conversion to a low impedance voltage signal prior to being processed by data acquisition or readout devices. The conversion can be done in two ways:



Charge Mode Force Sensor



Low Noise Cable



Dual Mode Charge Amplifier
(Low impedance output to Oscilloscope or DAQ)

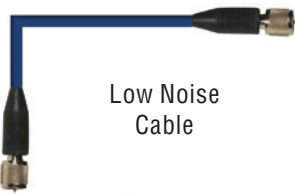

Low Noise Cable



In-line Charge Converter

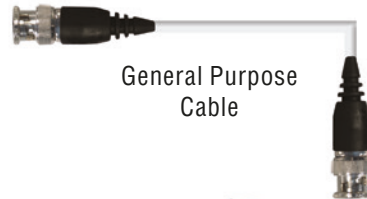

General Purpose Cable



Charge Mode Force Link



ICP® Signal Conditioner -
Powers Charge Converter
(Low impedance output to Oscilloscope or DAQ)

FORCE SENSOR INSTALLATION

MOUNTING PRECISION

PCB force sensors are precisely machined and assembled during the production process to maximize uniform transfer of force through the load bearing surfaces of the sensor. Force sensor assemblies require precise alignment of the sensor and contact surfaces to eliminate potential causes for test error. Proper mounting of PCB force rings includes:

- Prepare Mating Surfaces – flat and parallel to within 0.001 in (0.03 mm) total indicated runout and free of any debris. Finish surfaces should be ground smooth to at least 125 microinches (3.2 micrometers).
- Monitor Fastener Torque – Excessive fastener torque during assembly and preload can transfer shear load into the force ring and potentially damage the sensor. Observe the following precautions, including those in the specific sensor product manual:
 - Utilize antifriction washers and fasteners with alignment bushings.
 - Apply a thin layer of lubricant on mounting surfaces during installation (creates better contact between the sensor and mounting surface).
- Careful handling – shock loads from metal to metal impact can damage quartz elements.
- Consider assembly materials and related impact / damping potential.

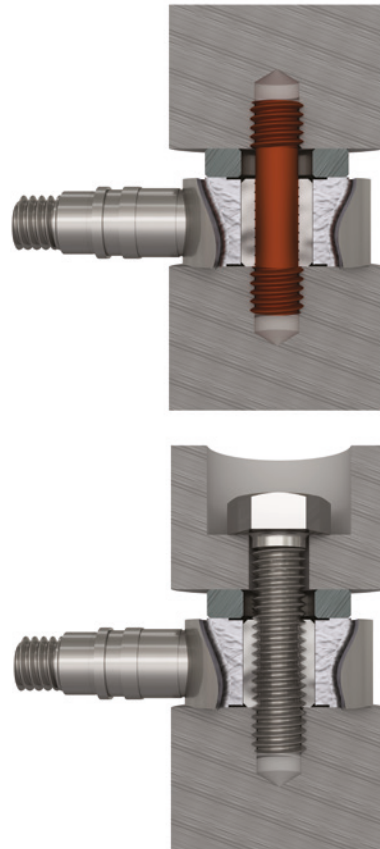

FORCE TRANSFER

- Minimize side / edge loading or bending moments in assemblies.
- Position sensors with axial loading only.
- Tension measurements require proper preloading (see force link assemblies – factory preloaded).
- Preloading a sensor off alignment can mechanically deform the sensor and crack the sensing element internally – output could be reduced or zero, factory evaluation or replacement may be required.



- Inner Ring damage can be caused by either lack of a pilot bushing or improper preload alignment.
- Outer Ring damage can be caused by either improper alignment during preload or poor load transfer path, potentially damaging the sensing element and/or rupturing the outer case as shown here.

AC COUPLED OUTPUT VS. DC COUPLED OUTPUT

- The following graph details a cyclical impulse in both AC and DC coupled modes, highlighting the DC offset that is removed by the signal conditioner.
- Note the low frequency content within only the DC Coupled signal after FFT to Frequency Domain (Amplitude vs Frequency). This is lost in AC Coupled mode.

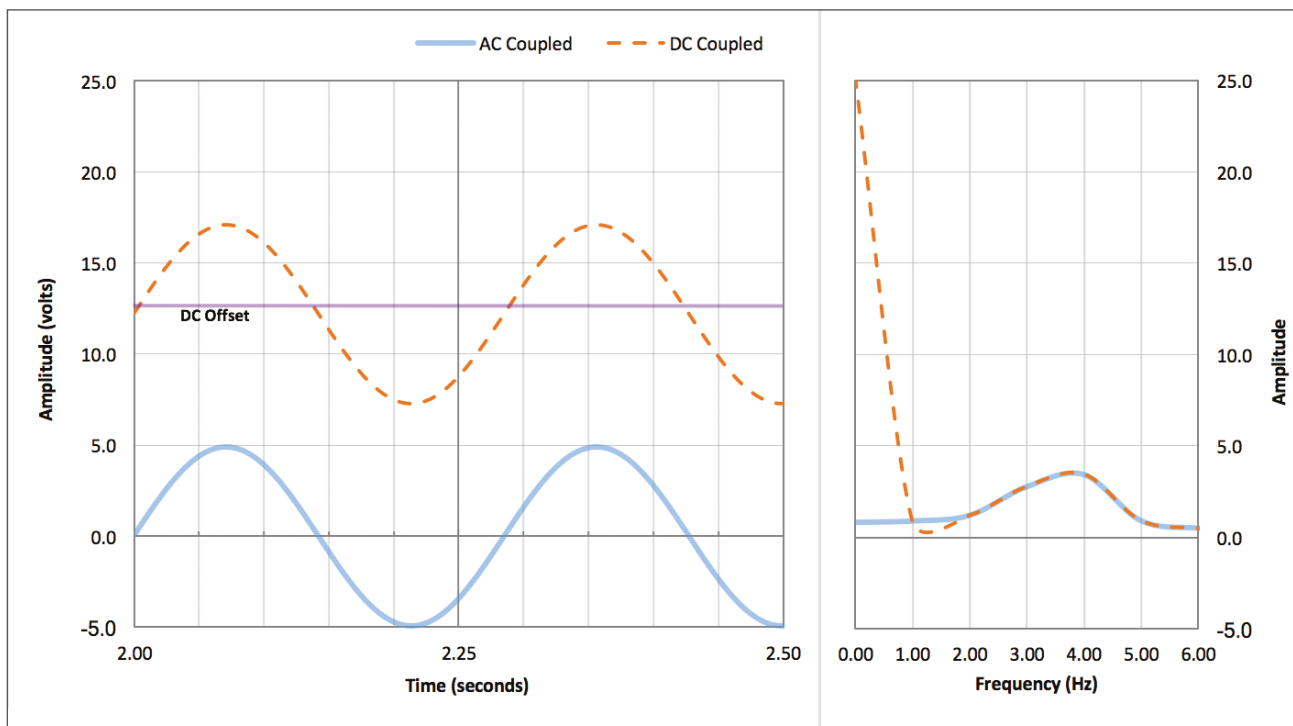

LONG DURATION EVENTS AND DTC

It is often desired to measure an input pulse lasting a few seconds in duration. This is especially true with force sensor applications where static calibration or quasi-static measurements take place. Before performing tests of this nature, it is important to DC couple the entire monitoring system (signal conditioner and data acquisition) to prevent rapid signal loss.

The general rule of thumb for such measurements is that the output signal loss and time elapsed over the first 10% of a DTC have a one to one relationship. If a sensor has a 500 second DTC, over the first 50 seconds, 10% of the original input signal will have decayed. For 1% accuracy, data should be taken in the first 1% of the DTC. If 8% accuracy is acceptable, the measurement should be taken within 8% of the DTC, and so forth.

Left unchanged, the signal will naturally decay toward zero. This will take approximately 5 times the DTC.

FREQUENCY RESPONSE

DISCHARGE TIME CONSTANT

- Discharge Time Constant (DTC) is the time (usually in seconds) required for an AC coupled device or measuring system to discharge its signal to 37% of the original value from a step change of measurand.
- Follows RC circuit principles where an instantaneous charge immediately begins dissipating at an exponential rate.
- ICP[®] sensors have fixed DTC based on the values of the internal RC network. When used in AC coupled systems, (sensor, cable, and ICP[®] signal conditioner) the sensor will take on the DTC characteristics of the ICP[®] sensor or signal conditioner (whichever is shortest). In charge mode sensors, the DTC is dictated by choice of charge amplifier or in-line charge converter and system resistance/capacitance.

Where:

- q = instantaneous charge (pC)
- Q = initial quantity of charge (pC)
- R = bias (or feedback) resistor value (ohms)
- C = total (or feedback) capacitance (pF)
- t = any time after t_0 (sec)
- e = base of natural log (2.718)

LOW FREQUENCY RESPONSE

In ICP[®] sensors, the low frequency response is dictated by the sensor electronics. Charge mode sensors do not include low frequency response or DTC in their specifications because they are dependent on the specific charge converter or amplifier used. When using charge mode sensors, refer to the specifications of the specific signal converter for low frequency and time constant information.

ICP[®] sensors have internal microelectronics that perform the conversion from a high impedance charge to a low impedance voltage signal. The low frequency roll off characteristics are included on ICP[®] sensor datasheets. Example specifications are included in the table on the next page.

The graphic below shows the relationship between sensitivity and frequency:

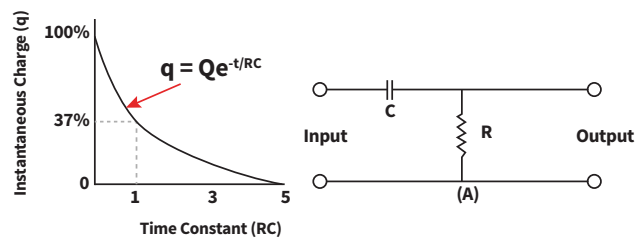
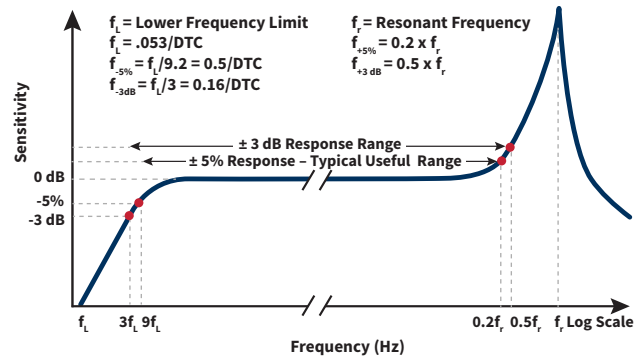

RESONANT FREQUENCY

At the component level, force sensors capabilities follow a similar curve to that shown above with a resonant frequency limit but they tend to take on the characteristics of the systems they are installed with. Their frequency response tends to be dependent on the stiffness of the overall system, related preloading, and coupling dynamics. Characterization of the installed system is often recommended to determine the frequency measurement threshold. Force test fixtures commonly exhibit natural frequencies in the 2,000 to 4,000 Hz and it is rare to use force sensors beyond these limits.

TYPICAL PERFORMANCE SPECIFICATIONS

| ICP® Force Ring | Model 205C | |
|--------------------------------|---|----------------|
| Sensitivity | 0.08 mV/lb | 17.98 mV/kN |
| Measurement Range (Comp) | ≤ 60,000 lb | ≤ 266.9 kN |
| Max Static Force (Compression) | ≤ 70,000 lb | ≤ 311.4 kN |
| Low Frequency Response | 0.0003 Hz, calculated from discharge time constant. | |
| Upper Frequency Limit | 50,000 Hz | |
| Non-Linearity | ≤ 1.5 % Full Scale | |
| Environmental | | |
| Temperature Range (Operating) | -65 to +250 °F | -54 to +121 °C |
| Electrical | | |
| Discharge Time Constant | ≥ 2,000 sec at room temperature | |
| Constant Current Excitation | 2 to 20 mA | |
| Output Polarity | Positive in Compression | |
| Physical | | |
| Preload | 12,000 lb | 53.379 kN |
| Stiffness | 40 lb/μin | 7 kN/μm |

| Charge Force Ring | Model 215B | |
|--------------------------------|---|----------------|
| Sensitivity | 18 pC/lb | 4,047 pC/kN |
| Measurement Range (Comp) | ≤ 60,000 lb | ≤ 266.9 kN |
| Max Static Force (Compression) | ≤ 70,000 lb | ≤ 311.4 kN |
| Low Frequency Response | Low frequency response is determined by external signal conditioning electronics. | |
| Upper Frequency Limit | 50,000 Hz | |
| Non-Linearity | ≤ 1.5 % Full Scale | |
| Environmental | | |
| Temperature Range (Operating) | -100 to +400 °F | -73 to +204 °C |
| Electrical | | |
| Capacitance (Typical) | 38 pF | |
| Insulation Resistance | ≥ 1.0 E ¹² ohms | |
| Output Polarity | Negative in Compression | |
| Physical | | |
| Preload | 12,000 lb | 53.379 kN |
| Stiffness | 40 lb/μin | 7 kN/μm |

EFFECT OF EXCITATION VOLTAGE ON THE DYNAMIC RANGE OF ICP® SENSORS

The specified excitation voltage for all standard ICP® sensors and amplifiers is generally within the range of +18 to +30 volts. The effect of this range is shown in the chart at right.

To explain the chart, the following values will be assumed:

- V_B = Sensor Bias Voltage = 10 VDC
- V_{S1} = Supply Voltage 1 = 24 VDC
- V_{E1} = Excitation Voltage 1 = $V_{S1} - 1 = 23$ VDC
- V_{S2} = Supply Voltage 2 = 18 VDC
- V_{E2} = Excitation Voltage 2 = $V_{S2} - 1 = 17$ VDC

Note that an approximate 1 volt drop across the current limiting diode (or equivalent circuit) must be maintained for correct current regulation.

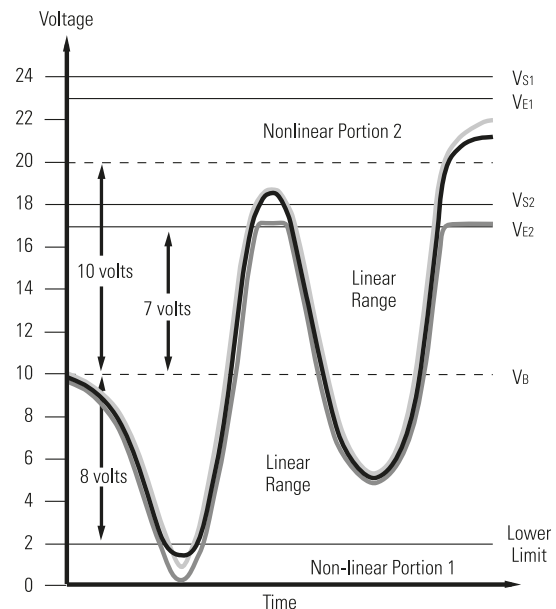
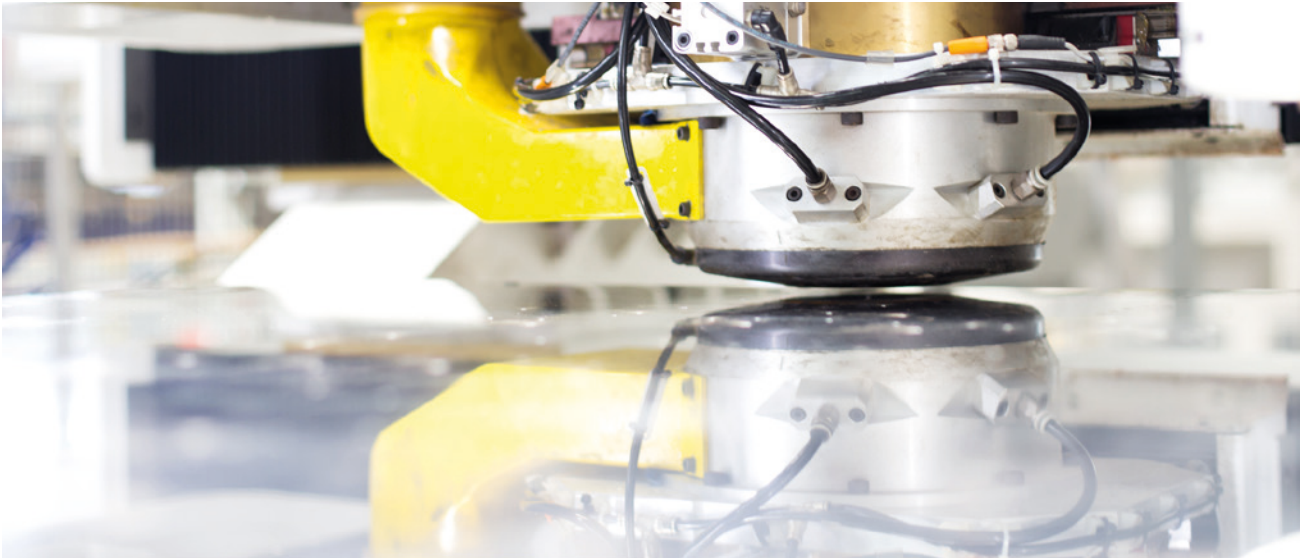

Figure 9. — Input Measurand (signal)
 - - - Output Signal (18 VDC supply)
 . . . Output Signal (24 VDC supply)

STRAIN SENSORS



STRAIN GAGES VS DYNAMIC STRAIN SENSORS WITH ICP®

Traditional strain measurement relies upon resistive strain gages bonded to the surface of the object under test in a 4-element strain gage bridge resulting in the Wheatstone Bridge Circuit. Wheatstone Bridges for strain are commonly used for static measurement and are common to load cells. Although traditional strain gages are low cost, they require suitable adhesive for bonding, have limited dynamic use up to 12 kHz, and are destroyed if removed.

PCB has combined piezoelectric crystals and ICP® technologies for use in dynamic strain measurement. The resulting sensors measure high frequency changes in strain with exceptional linearity over their measurement range. Sensitivity is specified for each sensor in millivolts per microstrain ($mV/\mu\epsilon$) with full scale output of 5.0 volts. These sensors have two mounting options: to be adhesive bonded to the dynamically loaded structure or mounted with a single through-bolt. The through-bolt design relies upon mechanical friction of contact pads and senses the change in strain between the pads.

TYPICAL WHEATSTONE BRIDGE FOR STATIC STRAIN GAGE

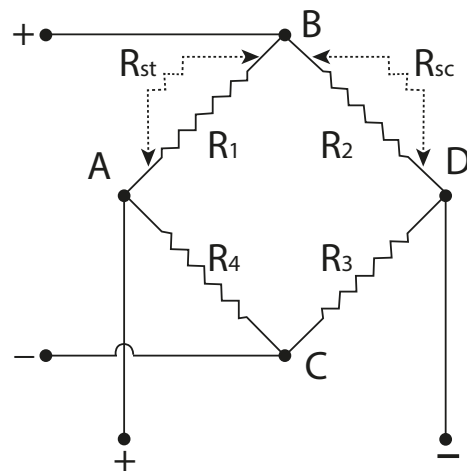



740B02 APPLICATIONS:

Titanium-housed alternative to bonded-foil strain gage using a quartz sensing element with ICP® piezoelectric output. They are easily applied and removed quickly without damage.

- Localized wing deflection
- Composite pressure vessel fatigue analysis
- Active vibration control
- Noise path and modal transfer path analysis

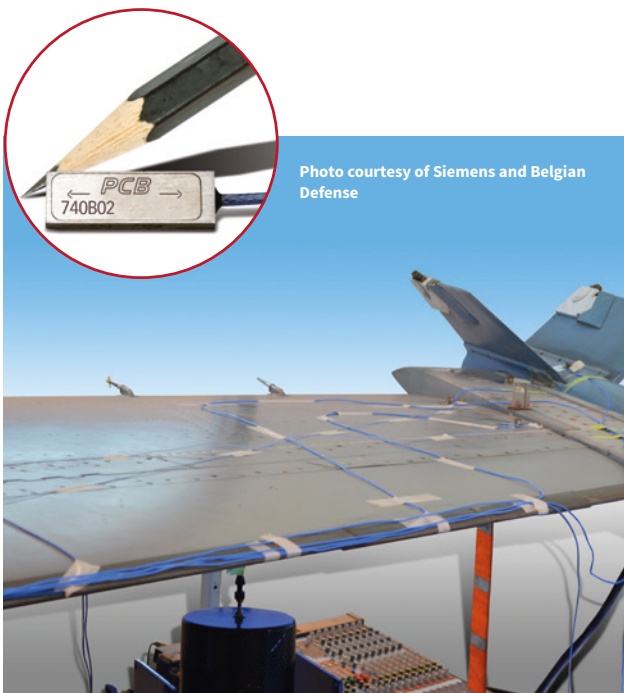

Model 740B02 strain sensors installed on a composite wing structure.



RHM240A02



RHM240M40

RHM240 SERIES APPLICATIONS:

Developed to indirectly measure repetitive impulse loading of machinery structures such as in press force/crimping or tooling fatigue tracking.

- Machine Frame Deflection - during pressing, crimping, welding for quality control
- Machine press overload protection
- Monitor manufacturing process repeatability
- Detection of installed stress on critical equipment

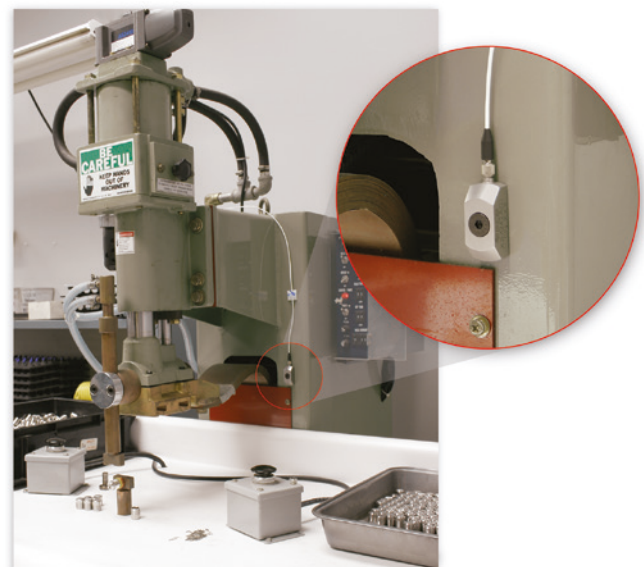
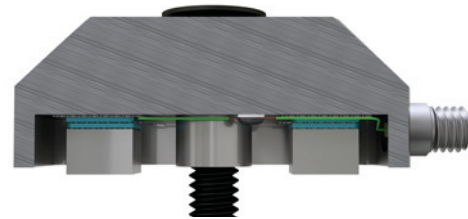

The RHM240 series strain sensor monitors press-fit forces to ensure quality end products.

FORCE SENSOR OR LOAD CELL?

The sensor names – force sensor or load cell – are sometimes used interchangeably, but they are not the same. A quartz force sensor is a piezoelectric device for dynamic measurement. Load cell terminology more commonly refers to a strain gage type of static force sensor. PCB specializes in dynamic force measurement with piezoelectric technology and steady state force measurement with load cells using strain gage technology. Each of these technologies has their own inherent benefits and challenges under certain applications:

Stiffness – Quartz force sensors are typically ten times stiffer than resistive-element based load cells. This also results in frequency range being 10x that of traditional load cells.

Wide Linear Measurement Range – One piezoelectric quartz force sensor covers the linear range of several strain gage load cells. They are able to zoom in the working range up to 1,000 times or more.

Temperature Range – Charge mode quartz force sensors can be used up to 400 °F (204 °C). Strain gages are typically limited to 200 °F (93 °C).

Size – A 5,000 lb (22 kN) quartz force sensor has a 0.75 inch (19 mm) diameter compared to a 3-4 inch (76-102 mm) diameter for a strain gage of the same capacity.



FORCE LINK (ICP® OR CHARGE)

- Force ring that is preloaded using integrated threaded mounting hardware
- Easily installed between two parts of a test structure
- Applications include tensile testing, press monitoring, and push rod testing



GENERAL PURPOSE (ICP® OR CHARGE)

- Internally preloaded
- Tapped holes on top and bottom surfaces
- Can be used for many dynamic force/tension applications



FORCE RING (ICP® OR CHARGE)

- Needs external preload with mounting stud
- Installed between two parts of test structure
- Applications include crimping, material testing, and punch pressing



3-COMPONENT FORCE RING (ICP® OR CHARGE)

- Triaxial force sensors capable of measuring in three orthogonal directions
- Requires external preload with mounting stud
- Applications include force limited vibration, engine mount analysis, and biomechanics



3-COMPONENT FORCE LINK (ICP® OR CHARGE)

- Triaxial force sensors capable of measuring in three orthogonal directions
- Preloaded by installing 3-component force ring between two mounting plates with a mounting stud
- Applications include force limited vibration, impact testing, and force plates



IMPACT FORCE SENSOR (ICP®)

- Integrated impact cap
- Tapped hole on bottom surface for stud mounting
- Applications include impact testing, drop testing, and stamping presses



FATIGUE RATED LOW PROFILE LOAD CELLS

- FS capacities from 250 lb to 500 klb
- Overload capability 200 to 300% FS
- Temperature, barometric, and moment compensated
- Applications include a variety of transportation, structural and medical device testing

COMBINING MULTIPLE FORCE SENSORS INTO ARRAYS:

Complex force arrays typically involve summation of forces (and moments if triaxial sensors are used). There are two methods to do this when using PCB piezoelectric force sensors:

- **Post-data acquisition**, (most common) mathematically sum forces and moments about center using derived calculations such as shown below to account for sensor distance from centerline.
- **Signal Summing**, sum forces and moments about center using derived calculations such as shown below to account for sensor distance from centerline.

Three Axis ICP® Force Plate (note all axis are aligned)

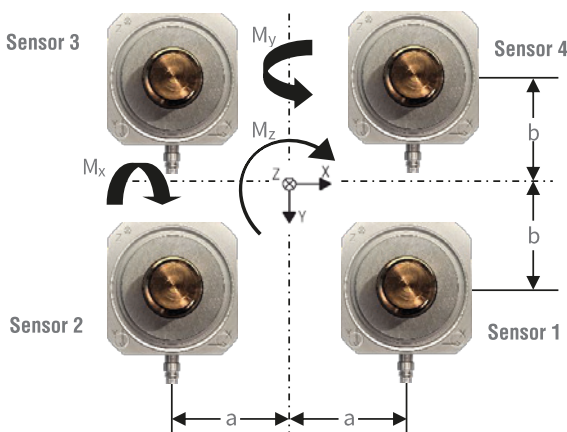

Single Axis Force Plate, Z axis only

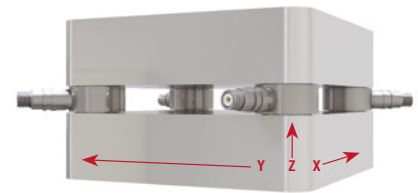

Axial Forces:

$$F_x = [F_{x1} + F_{x2} + F_{x3} + F_{x4}]$$

$$F_y = [F_{y1} + F_{y2} + F_{y3} + F_{y4}]$$

$$F_z = [F_{z1} + F_{z2} + F_{z3} + F_{z4}]$$

Moments about Center:

$$M_x = b * [F_{z1} + F_{z2} - F_{z3} - F_{z4}]$$

$$M_y = a * [-F_{z1} + F_{z2} + F_{z3} - F_{z4}]$$

$$M_z = b * [(F_{x3} + F_{x4}) - (F_{x1} + F_{x2})] + a * [(F_{y1} + F_{y4}) - (F_{y2} + F_{y3})]$$

